

EMC Test Report

Client Name : Shen Zhen JHC Technology Development Co., LTD
Address : B, 3rd Fl, A Block Junxiangda Bldg., No.9
Zhongshanyuan Rd. West, Tongle Village, Nanshan
District, Shenzhen City, China, 518052
Product Name : Fanless In-Vehicle Computer
Date : Mar. 13, 2020

Shenzhen Anbotek Compliance Laboratory Limited



Contents

1. General Information.....	5
1.1. Client Information.....	5
1.2. Description of Device (EUT).....	5
1.3. Auxiliary Equipment Used During Test.....	6
1.4. Description of Test Modes.....	7
1.5. Test Summary.....	7
1.6. Test Equipment List.....	8
1.7. Description of Test Facility.....	10
1.8. EMS Performance Criteria.....	10
2. Power Line Conducted Emission Test.....	11
2.1. Test Standard and Limit.....	11
2.2. Test Setup.....	11
2.3. EUT Configuration on Measurement.....	11
2.4. Operating Condition of EUT.....	11
2.5. Test Procedure.....	12
2.6. Test Results.....	12
3. Radiated Emission Test.....	17
3.1. Test Standard and Limit.....	17
3.2. Test Setup.....	17
3.3. EUT Configuration on Measurement.....	18
3.4. Operating Condition of EUT.....	18
3.5. Test Procedure.....	18
3.6. Test Results.....	18
4. Electrostatic Discharge Immunity Test.....	25
4.1. Test Standard and Level.....	25
4.2. Test Setup.....	25
4.3. EUT Configuration on Measurement.....	25
4.4. Operating Condition of EUT.....	25
4.5. Test Procedure.....	26
4.6. Test Results.....	26
5. RF Field Strength Susceptibility Test.....	28
5.1. Test Standard and Level.....	28
5.2. Test Setup.....	28
5.3. EUT Configuration on Measurement.....	29
5.4. Operating Condition of EUT.....	29
5.5. Test Procedure.....	29
5.6. Measuring Results.....	29
6. Electrical Fast Transient/Burst Immunity Test.....	31
6.1. Test Standard and Level.....	31
6.2. Test Setup.....	31

6.3. EUT Configuration on Measurement.....	31
6.4. Operating Condition of EUT.....	32
6.5. Test Procedure.....	32
6.6. Test Results.....	32
7. Surge Immunity Test.....	34
7.1. Test Standard and Level.....	34
7.2. Test Setup.....	34
7.3. EUT Configuration on Measurement.....	34
7.4. Operating Condition of EUT.....	34
7.5. Test Procedure.....	35
7.6. Test Results.....	35
8. Injected Currents Susceptibility Test.....	37
8.1. Test Standard and Level.....	37
8.2. Test Setup.....	37
8.3. EUT Configuration.....	37
8.4. Operating Condition of EUT.....	37
8.5. Test Procedure.....	38
8.6. Test Results.....	38
9. Magnetic Field Susceptibility Test.....	40
9.1. Test Standard and Level.....	40
9.2. Test Setup.....	40
9.3. EUT Configuration on Measurement.....	41
9.4. Operating Condition of EUT.....	41
9.5. Test Procedure.....	41
9.6. Test Results.....	41
APPENDIX I -- TEST SETUP PHOTOGRAPH.....	43
APPENDIX II -- EXTERNAL PHOTOGRAPH.....	47
APPENDIX III -- INTERNAL PHOTOGRAPH.....	51



TEST REPORT

Applicant : Shen Zhen JHC Technology Development Co., LTD

Manufacturer : Shen Zhen JHC Technology Development Co., LTD

Product Name : Fanless In-Vehicle Computer

Model No. : SIGM-3250/S001, SIGM-3250/S002, SIGM-3250/S003, SIGM-3250/S004
SIGM-3250/T001, SIGM-3250/T002, SIGM-3250/T003, SIGM-3250/T004

Trade Mark : JHCTECH

Rating(s) : DC 48-110V, 1A

**Test Standard(s) : EN 50155: 2017;
EN 50121-3-2: 2016;
(IEC 61000-4-2; IEC 61000-4-3; IEC 61000-4-4;
IEC 61000-4-5; IEC 61000-4-6; IEC 61000-4-8)**

The device described above is tested by Shenzhen Anbotek Compliance Laboratory Limited to determine the maximum emission levels emanating from the device and the severe levels of the device can endure and its performance criterion. The measurement results are contained in this test report and Shenzhen Anbotek Compliance Laboratory Limited is assumed full of responsibility for the accuracy and completeness of these measurements. Also, this report shows that the EUT (Equipment Under Test) is technically compliant with the EN 50121-3-2 and EN 50155 requirements.

This report applies to above tested sample only and shall not be reproduced in part without written approval of Shenzhen Anbotek Compliance Laboratory Limited.

Date of Receipt: Feb. 25, 2020

Date of Test: Feb. 25~Mar. 13, 2020

Prepared By:

Winnie Huang

(Engineer / Winnie Huang)

Reviewer:

Well Wang

(Supervisor / Well Wang)

Approved & Authorized Signer:

Tom Chen

(Manager / Tom Chen)

1. General Information

1.1. Client Information

Applicant	:	Shen Zhen JHC Technology Development Co., LTD
Address	:	B, 3rd Fl, A Block Junxiangda Bldg., No.9 Zhongshanyuan Rd. West, Tongle Village, Nanshan District, Shenzhen City, China, 518052
Manufacturer	:	Shen Zhen JHC Technology Development Co., LTD
Address	:	B, 3rd Fl, A Block Junxiangda Bldg., No.9 Zhongshanyuan Rd. West, Tongle Village, Nanshan District, Shenzhen City, China, 518052
Factory	:	Shen Zhen JHC Technology Development Co., LTD
Address	:	B, 3rd Fl, A Block Junxiangda Bldg., No.9 Zhongshanyuan Rd. West, Tongle Village, Nanshan District, Shenzhen City, China, 518052

1.2. Description of Device (EUT)

Product Name	:	Fanless In-Vehicle Computer
Model No.	:	SIGM-3250/S001, SIGM-3250/S002, SIGM-3250/S003, SIGM-3250/S004 SIGM-3250/T001, SIGM-3250/T002, SIGM-3250/T003, SIGM-3250/T004 (Note: All samples are the same except the model number & S series belongs to full function, T series simplifies interface, so we prepare "SIGM-3250/S001" for test only.)
Trade Mark	:	JHCTECH
Test Power Supply	:	DC 110V
Test Sample No.	:	1-1-1
Product Description	:	Adapter: N/A

Remark: (1) For a more detailed features description, please refer to the manufacturer's specifications or the User's Manual.

1.3. Auxiliary Equipment Used During Test

MONITOR	:	Manufacturer: DELL
		M/N: E1914Hf S/N: CN-034H2R-72872-419-AFJB Input:100V-240V, 1.5A, 50/60Hz TUV-GS, FCC, CE, KCC, VCCI
KEYBOARD	:	Manufacturer: DELL
		M/N: SK-8120 S/N: CN-0DJ365-71616-49J-0MVR-A00 Input Rating: DC 5V, 0.05A CE, FCC, VCCI, KCC, TUV-GS Cable: 1.8m, unshielded
MOUSE	:	Manufacturer: DELL
		M/N: MS111-T S/N: CN-0KW2YH-71616-488-1CBJ Input Rating: DC 5V, 0.1A Cable: 1.8m, unshielded CE, FCC, VCCI, KCC, TUV-GS



1.4. Description of Test Modes

Pretest Modes	Descriptions
Mode 1	DP Mode
Mode 2	VGA Mode

For Mode 1~ Mode 2 Block Diagram of Test Setup

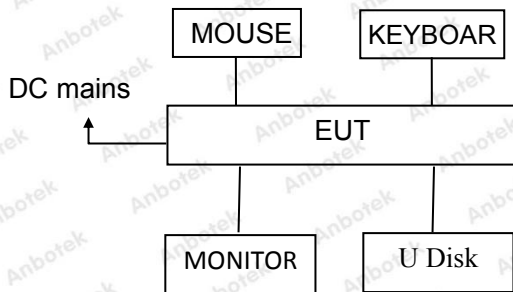

1.5. Test Summary

Test Items	Test Modes	Status
Power Line Conducted Emission Test (150KHz To 30MHz)	All Mode	P
Radiated Emission Test (30MHz To 6GHz)	All Mode	P
Electrostatic Discharge immunity Test	All Mode	P
RF Field Strength susceptibility Test	All Mode	P
Electrical Fast Transient/Burst Immunity Test	All Mode	P
Surge Immunity Test	All Mode	P
Injected Currents Susceptibility Test	All Mode	P
Magnetic Field Susceptibility Test	All Mode	P
Voltage Dips and Interruptions Test	/	N
P) Indicates "PASS". N) Indicates "Not applicable".		

1.6. Test Equipment List

Conducted Emission Measurement

Item	Equipment	Manufacturer	Model No.	Serial No.	Last Cal.	Cal. Interval
1.	L.I.S.N. Artificial Mains Network	Rohde & Schwarz	ENV216	100055	Nov. 04, 2019	1 Year
2.	L.I.S.N. Artificial Mains Network	Schwarzbeck	NSLK 8127	8127386	Nov. 04, 2019	1 Year
3.	EMI Test Receiver	Rohde & Schwarz	ESCI	100627	Nov. 04, 2019	1 Year
4.	RF Switching Unit	Compliance Direction	RSU-M2	38303	Nov. 04, 2019	1 Year
5.	Software Name EZ-EMC	Ferrari Technology	ANB-03A	N/A	N/A	N/A

Radiated Emission Measurement

Item	Equipment	Manufacturer	Model No.	Serial No.	Last Cal.	Cal. Interval
1.	EMI Test Receiver	Rohde & Schwarz	ESR26	101481	Nov. 04, 2019	1 Year
2.	Bilog Broadband Antenna	Schwarzbeck	VULB9163	VULB 9163-289	Nov. 01, 2019	1 Year
3.	Pre-amplifier	SONOMA	310N	186860	Nov. 04, 2019	1 Year
4.	Software Name EZ-EMC	Ferrari Technology	ANB-03A	N/A	N/A	N/A
5.	Preamplifier	SKET Electronic	BK1G18G30 D	KD17503	Nov. 04, 2019	1 Year
6.	Double Ridged Horn Antenna	Instruments corporation	GTH-0118	351600	Nov. 01, 2019	1 Year

Electrostatic Discharge Measurement

Item	Equipment	Manufacturer	Model No.	Serial No.	Last Cal.	Cal. Interval
1.	ESD Simulators	emtest	ESD NX30.1	11891	Mar. 07, 2020	1 Year



Item	Equipment	Manufacturer	Model No.	Serial No.	Last Cal.	Cal. Interval
1	Signal Generator	Agilent	N5182A	MY48180656	Nov. 04, 2019	1 Year
2	Amplifier	Micotoop	MPA-80-1000-250	MPA1903096	Nov. 04, 2019	1 Year
3	Amplifier	Micotoop	MPA-1000-6000-100	MPA1903122	Nov. 04, 2019	1 Year
4	Log-Periodic Antenna	Schwarzbeck	VULP9118E	00992	Aug. 17, 2018	3 Year
5	Horn Antenna	Instruments corporation	GTH-0118	351600	Nov. 01, 2019	1 Year
6	Power Sensor	Agilent	E9301A	MY41498906	Nov. 04, 2019	1 Year
7	Power Sensor	Agilent	E9301A	MY41498088	Nov. 04, 2019	1 Year
8	Power Meter	Agilent	E4419B	GB40202909	Nov. 04, 2019	1 Year
9	Field Probe	ETS-Lindgren	HI-6006	00212747	Apr. 20, 2017	3 Year
10	software	EMtrace	EM 3	N/A	N/A	N/A

Electrical Fast Transient/Burst Immunity Measurement

Item	Equipment	Manufacturer	Model No.	Serial No.	Last Cal.	Cal. Interval
1.1	EFT Burst Simulator	PRIMA	EFT61004B	PR10114282	Nov. 04, 2019	1 Year
1.2	EFT-Clamp	PRIMA	EFT-Clamp	/	Nov. 04, 2019	1 Year
2.1	EFT Burst Simulator	TESEQ	NSG 3060	1480	Nov. 04, 2019	1 Year
2.2	CDN	TESEQ	CDN 3061	1408	Nov. 04, 2019	1 Year

Surge Measurement

Item	Equipment	Manufacturer	Model No.	Serial No.	Last Cal.	Cal. Interval
1.	Surge Generator	TESEQ	NSG 3060	1480	Nov. 04, 2019	1 Year
2.	CDN	TESEQ	CDN 3061	1408	Nov. 04, 2019	1 Year
3.	Telecom port surge generator	PMI	TW101	190411	Apr.17,2019	1 Year

Injected Currents Susceptibility Measurement

Item	Equipment	Manufacturer	Model No.	Serial No.	Last Cal.	Cal. Interval
1.	C/S Conducted Immunity Test System	FRANKONIA	CIT-10	126A1196/2012	Nov. 04, 2019	1 Year
2.	CDN	FRANKONIA	CDN - M2+M3	A2210178/2012	Nov. 04, 2019	1 Year
3.	6dB Attenuator	FRANKONIA	DAM 26W	1172202	Nov. 04, 2019	1 Year
4.	CIT-10	FRANKONIA	Version1.1.7	N/A	N.A	N/A
5.	EM-Clamp	FRANKONIA	EMCL-20	18101728-0103	May.19,2019	1 Year

Magnetic Field Immunity Test

Item	Equipment	Manufacturer	Model No.	Serial No.	Last Cal.	Cal. Interval
1.	Power Frequency Magnetic Field Generator	EVERFINE	EMS61000-8K	906002	Nov. 04, 2019	1 Year

1.7. Description of Test Facility

The test facility is recognized, certified, or accredited by the following organizations:

FCC-Registration No.: 184111

Shenzhen Anbotek Compliance Laboratory Limited, EMC Laboratory has been registered and fully described in a report filed with the (FCC) Federal Communications Commission. The acceptance letter from the FCC is maintained in our files. Registration No. 184111, September 27, 2019.

ISED-Registration No.: 8058A

Shenzhen Anbotek Compliance Laboratory Limited, EMC Laboratory has been registered and fully described in a report filed with the (ISED) Innovation, Science and Economic Development Canada. The acceptance letter from the ISED is maintained in our files. Registration 8058A, March 07, 2019.

Test Location

Shenzhen Anbotek Compliance Laboratory Limited.
1/F, Building D, Sogood Science and Technology Park, Sanwei community, Hangcheng Street, Bao'an District, Shenzhen, Guangdong, China.518128

1.8. EMS Performance Criteria

- √ A: Normal performance within the specification limits
- √ B: Temporary degradation or loss of function or performance which is self-recoverable
- √ C: Temporary degradation or loss of function or performance which requires operator intervention or system reset
- √ D: Degradation or loss of function which is not recoverable due to damage of equipment (components) or software, or loss of data

Note: The manufacturer's specification may define effects on the EUT which may be considered insignificant, and therefore acceptable.

This classification may be used as a guide in formulating performance criteria, by committees responsible for generic, product and product-family standards, or as a framework for the agreement on performance criteria between the manufacturer and the purchaser, for example where no suitable generic, product or product-family standard exists.



2. Power Line Conducted Emission Test

2.1. Test Standard and Limit

Test Standard	EN 50155 (EN 50121-3-2)
---------------	-------------------------

Limits for conducted emissions

Test Limit	Frequency (MHz)	At mains terminals (dB μ V)
		Quasi-peak Level
	0.15 ~ 0.50	99
	0.50 ~ 30.00	93

Remark: (1) The lower limit shall apply at the transition frequencies.

(2) This requirement refers to the industrial limit values but considering they have been defined to protect radio and TV sets and as the objective is not the same here, the applicable limit for railway applications have been relaxed by 20 dB to be more representative of potential problems. This product may cause radio interference in which

2.2. Test Setup

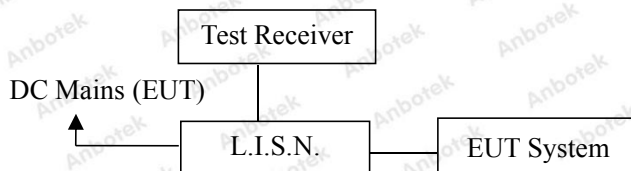

2.3. EUT Configuration on Measurement

The following equipments are installed on conducted emission measurement to meet EN 50155 requirements and operating in a manner which tends to maximize its emission characteristics in a normal application.

2.4. Operating Condition of EUT

2.4.1. Setup the EUT as shown in Section 2.2.

2.4.2. Turn on the power of all equipments.

2.4.3. Let the EUT work in test mode and measure it.

2.5. Test Procedure

The EUT is put on the plane 0.8 m high above the ground by insulating support and connected to the DC mains through Line Impedance Stability Network(L.I.S.N). This provided a 50ohm coupling impedance for the tested equipments. Both sides of DC line are investigated to find out the maximum conducted emission according to the EN 50121-3-2 regulations during conducted emission measurement.

The bandwidth of the field strength meter (R&S Test Receiver ESCI) is set at 9kHz in 150kHz~30MHz.

The frequency range from 150kHz to 30MHz is investigated for DC mains.

All the test results are listed in Section 2.6.

2.6. Test Results

PASS

The test curves are shown in the following pages.



Conducted Emission Test Data

Test Mode: DP Mode
 Test Site: 1# Shielded Room
 Test Specification: DC 110V
 Comment: Positive
 Temp.: 22.1°C Hum.: 55%

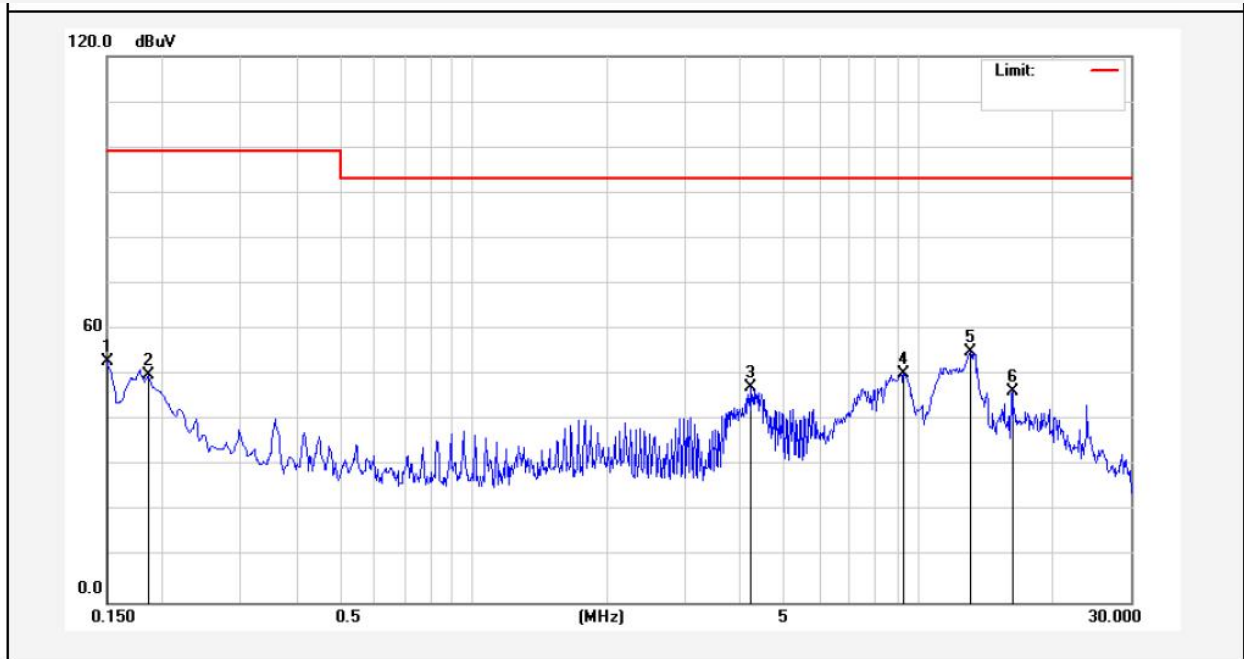

No.	Freq. (MHz)	Reading (dBuV)	Factor (dB)	Result (dBuV)	Limit (dBuV)	Over Limit (dB)	Detector	Remark
1	0.1500	33.09	19.90	52.99	99.00	-46.01	QP	
2	0.1860	29.93	19.90	49.83	99.00	-49.17	QP	
3	4.2140	27.00	20.19	47.19	93.00	-45.81	QP	
4	9.2620	30.01	20.32	50.33	93.00	-42.67	QP	
5	13.1220	34.72	20.29	55.01	93.00	-37.99	QP	
6	16.2260	26.04	20.28	46.32	93.00	-46.68	QP	

Note: Result=Reading+Factor Over Limit=Result-Limit

Conducted Emission Test Data

Test Mode: DP Mode
 Test Site: 1# Shielded Room
 Test Specification: DC 110V
 Comment: Negative
 Temp.: 22.1°C Hum.: 55%

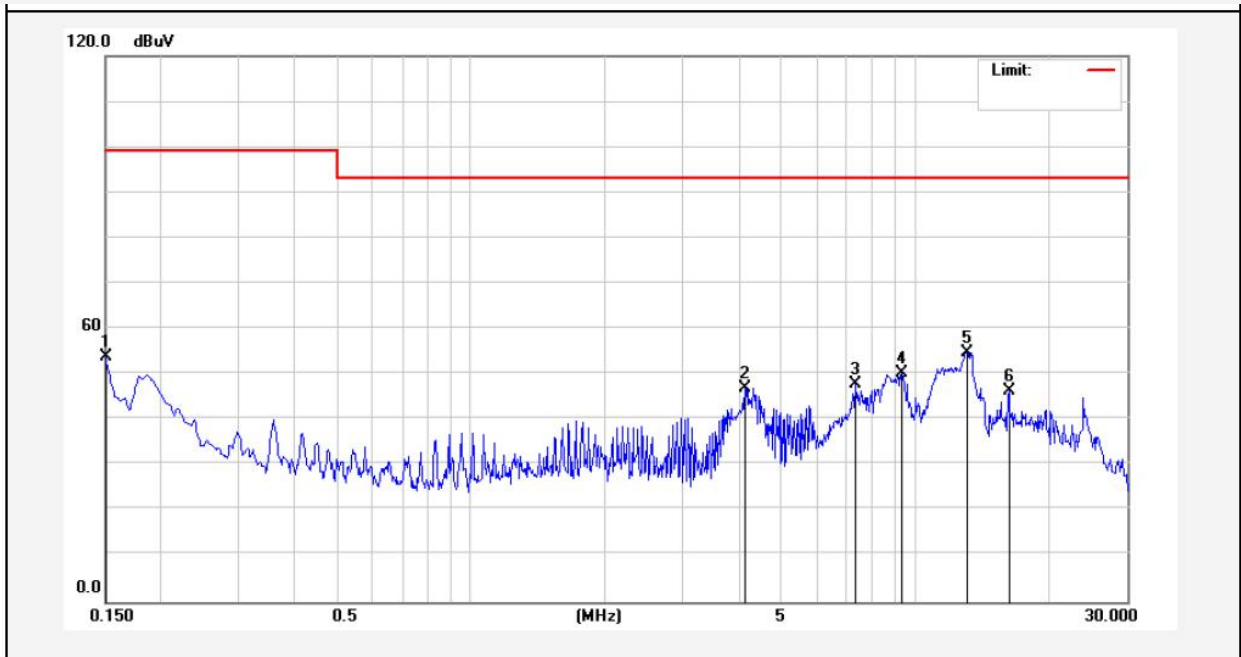

No.	Freq. (MHz)	Reading (dBuV)	Factor (dB)	Result (dBuV)	Limit (dBuV)	Over Limit (dB)	Detector	Remark
1	0.1500	33.82	19.90	53.72	99.00	-45.28	QP	
2	4.1540	26.82	20.18	47.00	93.00	-46.00	QP	
3	7.3580	27.45	20.27	47.72	93.00	-45.28	QP	
4	9.3220	29.83	20.32	50.15	93.00	-42.85	QP	
5	13.0580	34.50	20.29	54.79	93.00	-38.21	QP	
6	16.2260	25.96	20.28	46.24	93.00	-46.76	QP	

Note: Result=Reading+Factor Over Limit=Result-Limit

Conducted Emission Test Data

Test Mode: VGA Mode
 Test Site: 1# Shielded Room
 Test Specification: DC 110V
 Comment: Positive
 Temp.: 22.1°C Hum.: 55%

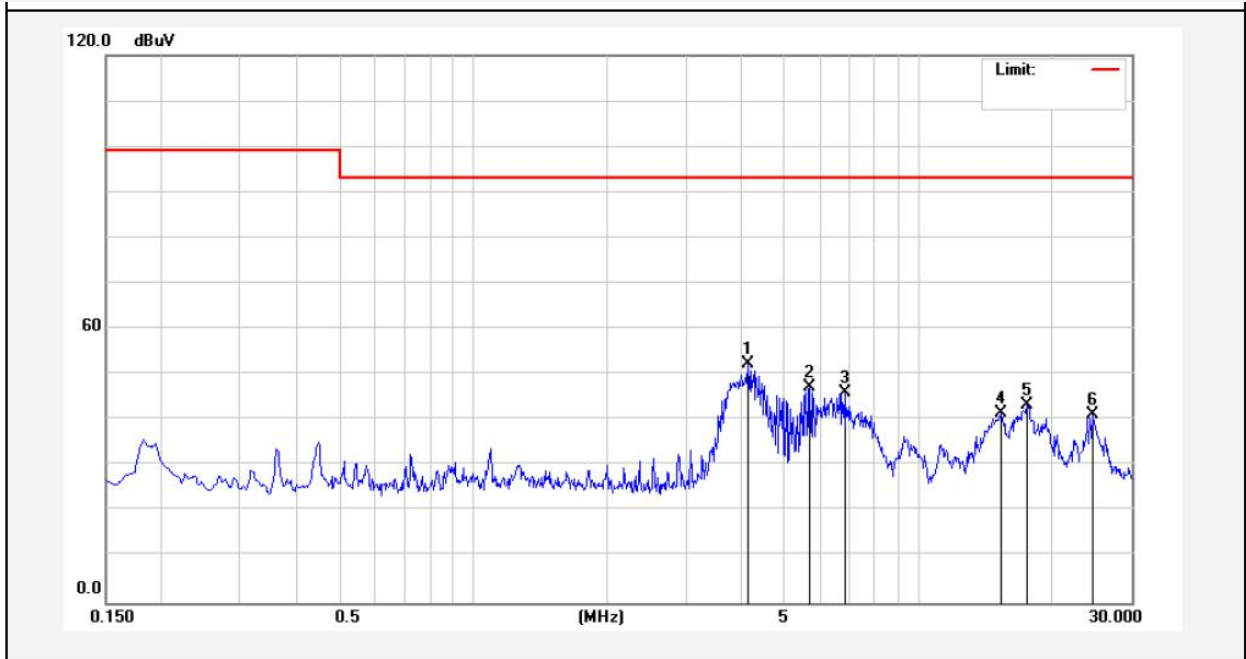

No.	Freq. (MHz)	Reading (dBUV)	Factor (dB)	Result (dBUV)	Limit (dBUV)	Over Limit (dB)	Detector	Remark
1	4.1540	32.22	20.18	52.40	93.00	-40.60	peak	
2	5.6979	27.08	20.23	47.31	93.00	-45.69	peak	
3	6.8300	25.74	20.26	46.00	93.00	-47.00	peak	
4	15.3740	21.27	20.27	41.54	93.00	-51.46	peak	
5	17.5380	22.90	20.30	43.20	93.00	-49.80	peak	
6	24.6420	20.85	20.28	41.13	93.00	-51.87	peak	

Note: Result=Reading+Factor Over Limit=Result-Limit

Conducted Emission Test Data

Test Mode: VGA Mode
 Test Site: 1# Shielded Room
 Test Specification: DC 110V
 Comment: Negative
 Temp.: 22.1°C Hum.: 55%

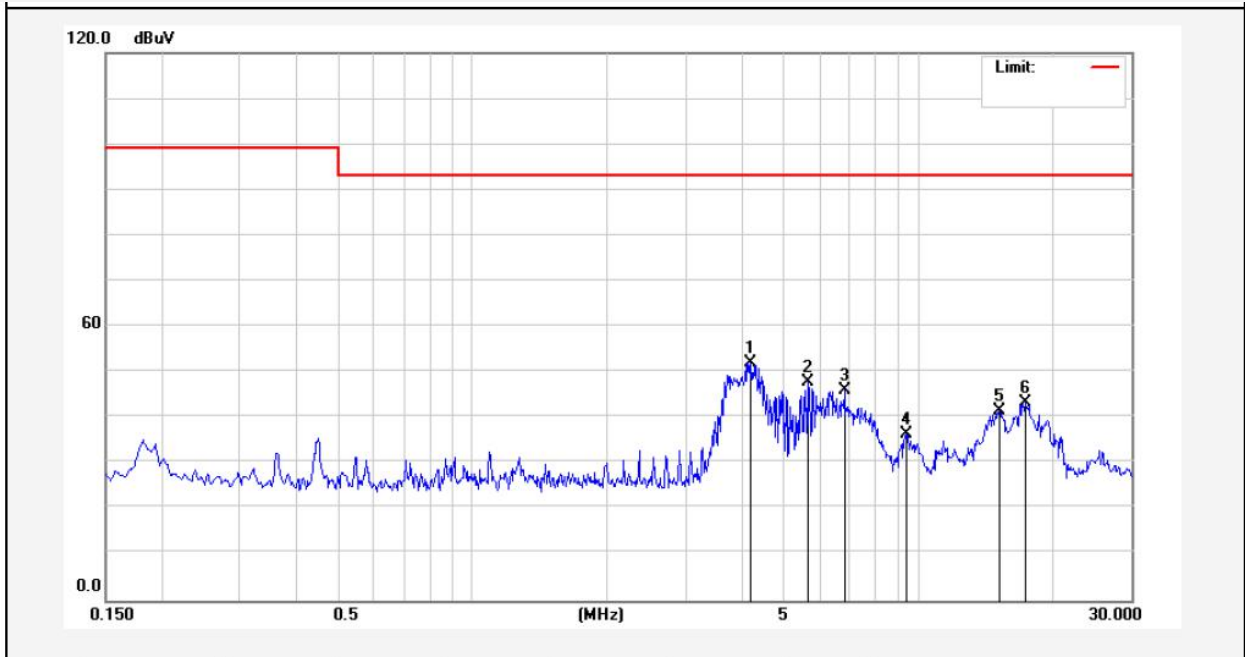

No.	Freq. (MHz)	Reading (dBuV)	Factor (dB)	Result (dBuV)	Limit (dBuV)	Over Limit (dB)	Detector	Remark
1	4.2099	31.98	20.19	52.17	93.00	-40.83	AVG	
2	5.6379	27.56	20.22	47.78	93.00	-45.22	peak	
3	6.8259	25.72	20.26	45.98	93.00	-47.02	peak	
4	9.3779	16.15	20.32	36.47	93.00	-56.53	peak	
5	15.1939	21.21	20.26	41.47	93.00	-51.53	peak	
6	17.3299	23.00	20.30	43.30	93.00	-49.70	peak	

Note: Result=Reading+Factor Over Limit=Result-Limit

3. Radiated Emission Test

3.1. Test Standard and Limit

Test Standard	EN 50155 (EN 50121-3-2)
---------------	-------------------------

Radiated Emission Test Limit

30~1000MHz				
Test Limit	Frequency (MHz)	DISTANCE (Meters)	FIELD STRENGTHS LIMIT (dB μ V/m)	
	30 ~ 230	3	50	
	230 ~ 1000	3	57	
1~6GHz				
Test Limit	Frequency (GHz)	DISTANCE (Meters)	FIELD STRENGTHS LIMIT	
	1 ~ 3	3	Average (dB μ V/m)	Peak (dB μ V/m)
			56	76
3 ~ 6	3	60	80	

Remark: (1) The smaller limit shall apply at the combination point between two frequency bands.
 (2) Distance refers to the distance in meters between the measuring instrument antenna and the closed point of any part of the EUT.
 (3) $3M \text{ Limit} = 10M \text{ Limit} + k$ $k = 20 \log(D1/D2) = 10$
 $3M \text{ Limit} = 10M \text{ Limit} + 10$
 (D1= 10M D2=3M)

3.2. Test Setup

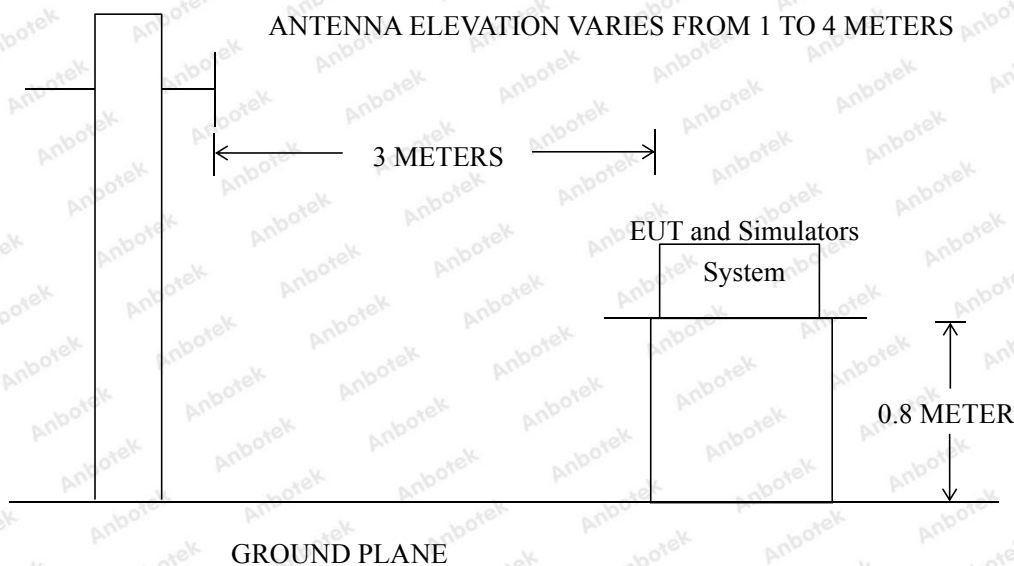

3.3. EUT Configuration on Measurement

The EN 50155 regulations test method must be used to find the maximum emission during radiated emission measurement.

3.4. Operating Condition of EUT

3.4.1. Setup the EUT as shown in Section 3.2.

3.4.2. Turn on the power of all equipments.

3.4.3. Let the EUT work in test mode and measure it.

3.5. Test Procedure

The EUT is placed on a turn table which is 0.8 meter high above the ground. The turn table can rotate 360 degrees to determine the position of the maximum emission level. The EUT is set 10 meters away from the receiving antenna which is mounted on a antenna tower. The antenna can be moved up and down from 1 to 4 meters to find out the maximum emission level. Bilog antenna is used as a receiving antenna. Both horizontal and vertical polarization of the antenna are set on test.

The bandwidth of the Receiver (ESCI) is set at 120kHz.

The EUT is tested in 9*6*6 Chamber.

The test results are listed in Section 3.6.

3.6. Test Results

PASS

The frequency range from 30MHz to 1000MHz is investigated.

The test curves are shown in the following pages.



Test item: Radiation Test **Polarization:** Horizontal
Standard: (RE)EN 50121-3-2_Class **Power Source:** DC 110V
Distance: 3m **Temp.(°C)/Hum.(%RH):** 23(°C)/56%RH
Test Mode: DP Mode

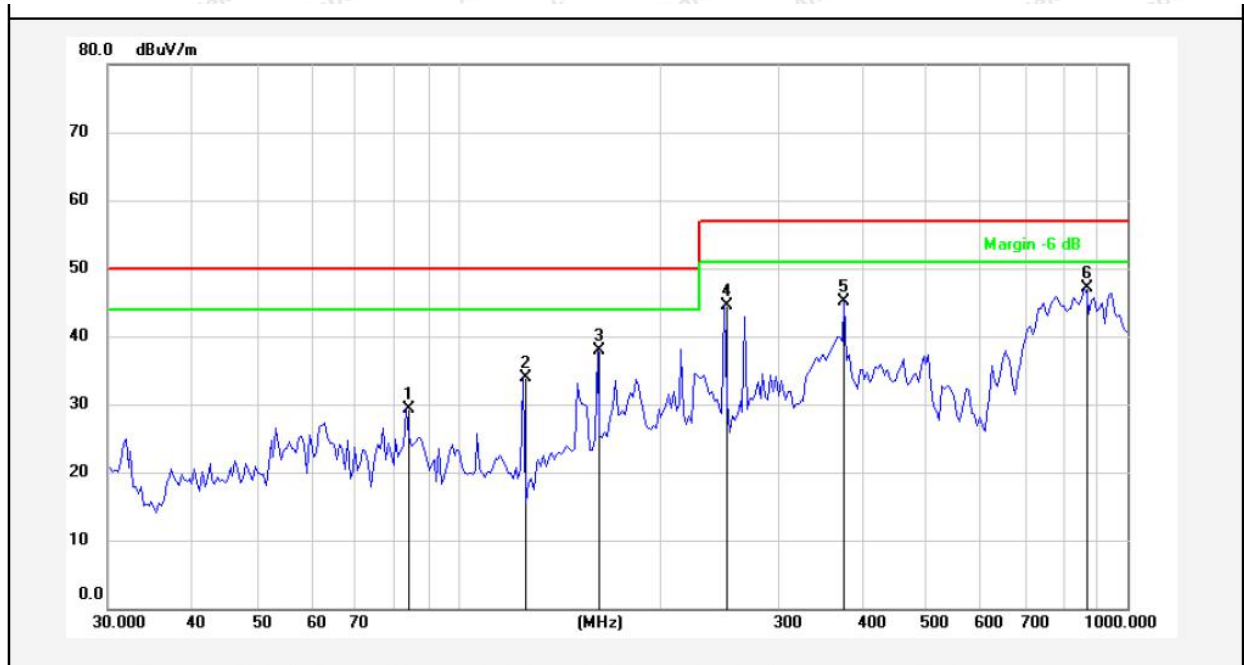

No.	Freq. (MHz)	Reading (dBuV)	Factor ()	Result (dBuV/m)	Limit (dBuV/m)	Over Limit (dB)	Detector	Height (cm)	degree (deg)	Remark
1	83.6688	51.47	-22.12	29.35	50.00	-20.65	peak			
2	125.2260	58.33	-24.49	33.84	50.00	-16.16	peak			
3	161.4742	61.54	-23.70	37.84	50.00	-12.16	peak			
4	250.3012	65.21	-20.71	44.50	57.00	-12.50	peak			
5	377.9211	61.36	-16.25	45.11	57.00	-11.89	peak			
6	861.5444	56.18	-9.11	47.07	57.00	-9.93	peak			

Note: Result=Reading+Factor Over Limit=Result-Limit

Test item: Radiation Test **Polarization:** Vertical
Standard: (RE)EN 50121-3-2_Class A_30~1000MHz **Power Source:** DC 110V
Distance: 3m **Temp.(°C)/Hum.(%RH):** 23(°C)/56%RH
Test Mode: DP Mode

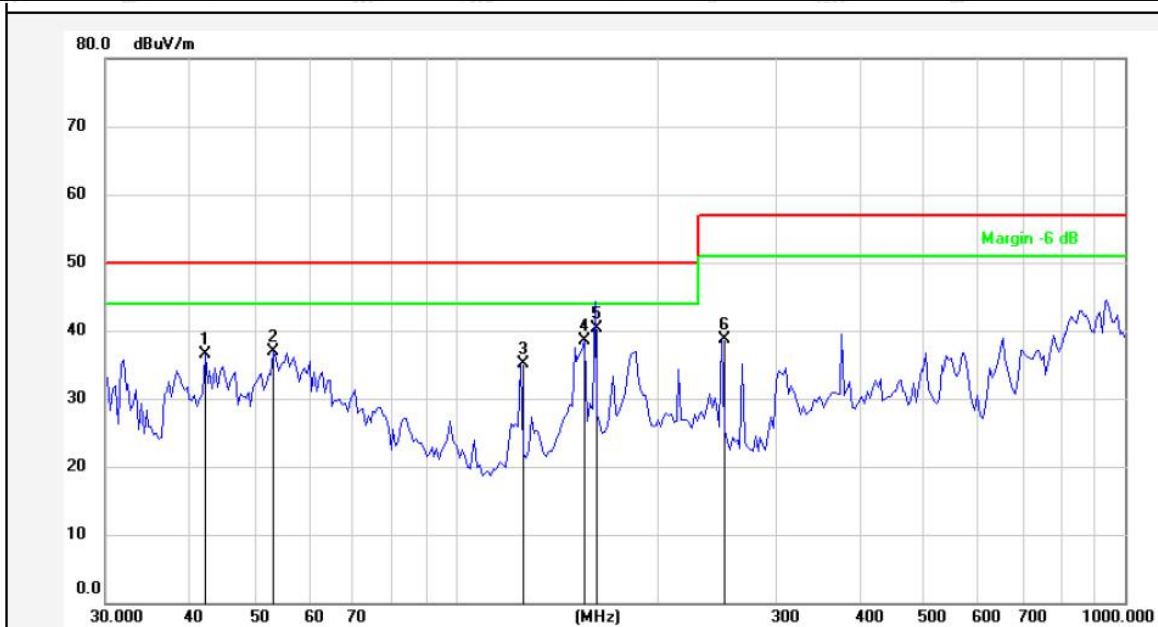

No.	Freq. (MHz)	Reading (dBuV)	Factor ()	Result (dBuV/m)	Limit (dBuV/m)	Over Limit (dB)	Detector	Height (cm)	degree (deg)	Remark
1	42.2281	52.04	-15.58	36.46	50.00	-13.54	peak			
2	53.5052	53.04	-16.06	36.98	50.00	-13.02	peak			
3	125.2260	54.20	-19.06	35.14	50.00	-14.86	peak			
4	155.9101	58.63	-20.09	38.54	50.00	-11.46	peak			
5	161.4742	60.25	-19.85	40.40	50.00	-9.60	QP	100	0	
6	250.3012	54.87	-16.19	38.68	57.00	-18.32	peak			

Note: Result=Reading+Factor Over Limit=Result-Limit

Test item:	Radiation Test	Polarization:	Horizontal
Standard:	(RE)EN 50121-3-2_Class A_30~1000MHz	Power Source:	DC 110V
Distance:	3m	Temp.(°C)/Hum.(%RH):	23(°C)/56%RH
Test Mode:	VGA Mode		

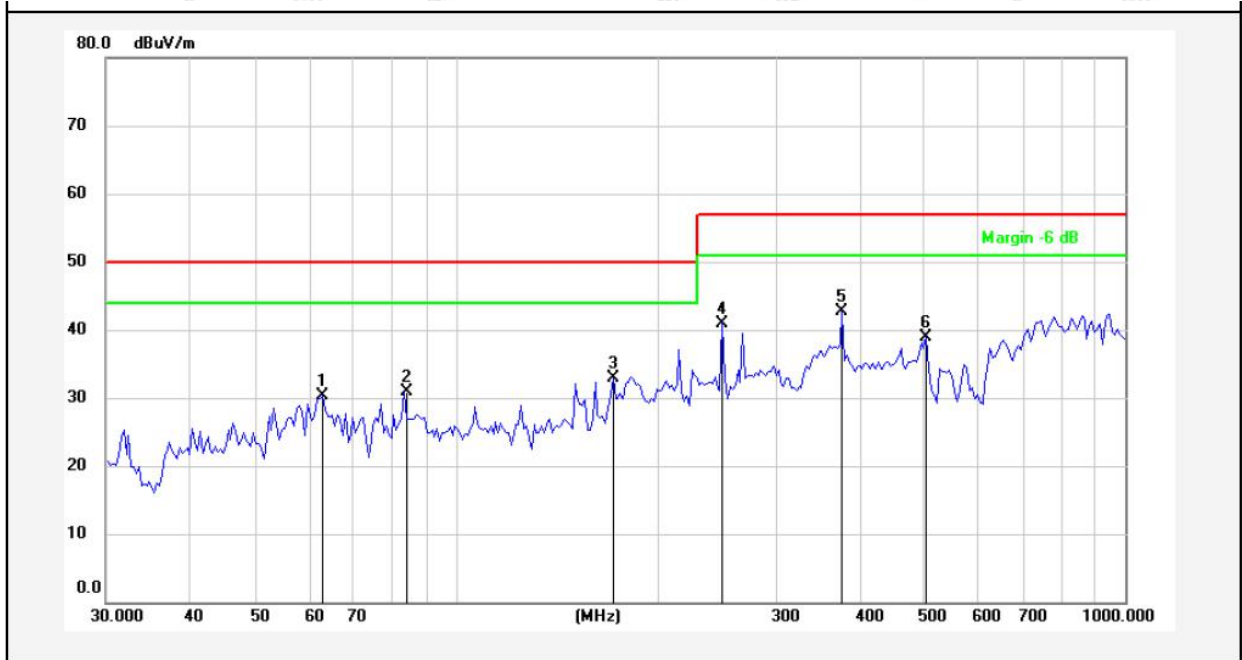

No.	Freq. (MHz)	Reading (dBuV)	Factor ()	Result (dBuV/m)	Limit (dBuV/m)	Over Limit (dB)	Detector	Height (cm)	degree (deg)	Remark
1	63.2023	48.93	-18.66	30.27	50.00	-19.73	peak			
2	83.6688	52.97	-22.12	30.85	50.00	-19.15	peak			
3	171.6930	55.50	-22.59	32.91	50.00	-17.09	peak			
4	250.3010	61.71	-20.71	41.00	57.00	-16.00	peak			
5	377.9211	58.86	-16.25	42.61	57.00	-14.39	peak			
6	504.7062	53.13	-14.28	38.85	57.00	-18.15	peak			

Note: Result=Reading+Factor Over Limit=Result-Limit

Test item: Radiation Test **Polarization:** Vertical
Standard: (RE)EN 50121-3-2_Class A_30~1000MHz **Power Source:** DC 110V
Distance: 3m **Temp.(°C)/Hum.(%RH):** 23(°C)/56%RH
Test Mode: VGA Mode

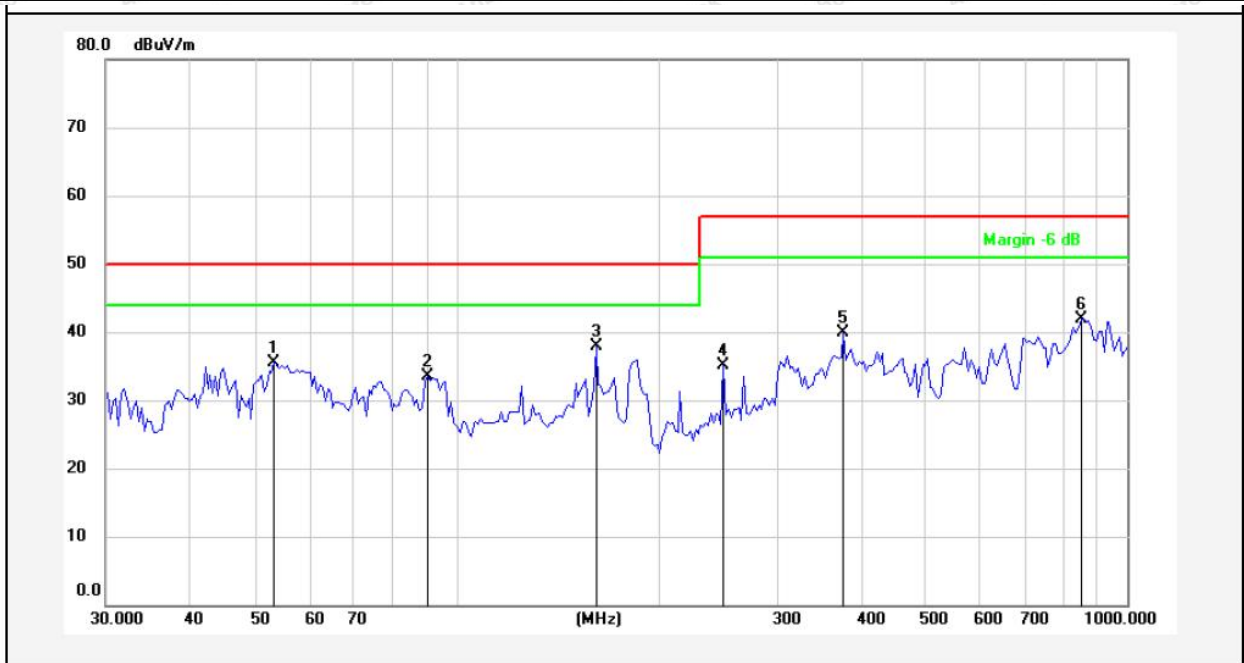

No.	Freq. (MHz)	Reading (dBuV)	Factor ()	Result (dBuV/m)	Limit (dBuV/m)	Over Limit (dB)	Detector	Height (cm)	degree (deg)	Remark
1	53.5052	51.54	-16.06	35.48	50.00	-14.52	peak			
2	90.5374	51.24	-17.81	33.43	50.00	-16.57	peak			
3	161.4740	57.75	-19.85	37.90	50.00	-12.10	peak			
4	250.3010	51.37	-16.19	35.18	57.00	-21.82	peak			
5	377.9211	55.21	-15.25	39.96	57.00	-17.04	peak			
6	854.0247	50.21	-8.21	42.00	57.00	-15.00	peak			

Note: Result=Reading+Factor Over Limit=Result-Limit

Test item:	Radiation Test	Polarization:	Horizontal
Standard:	(RE)EN 50121-3-2_Class A_1-6GHz	Power Source:	DC 110V
Distance:	3m	Temp.(°C)/Hum.(%RH):	23(°C)/54%RH
Test Mode:	DP Mode		

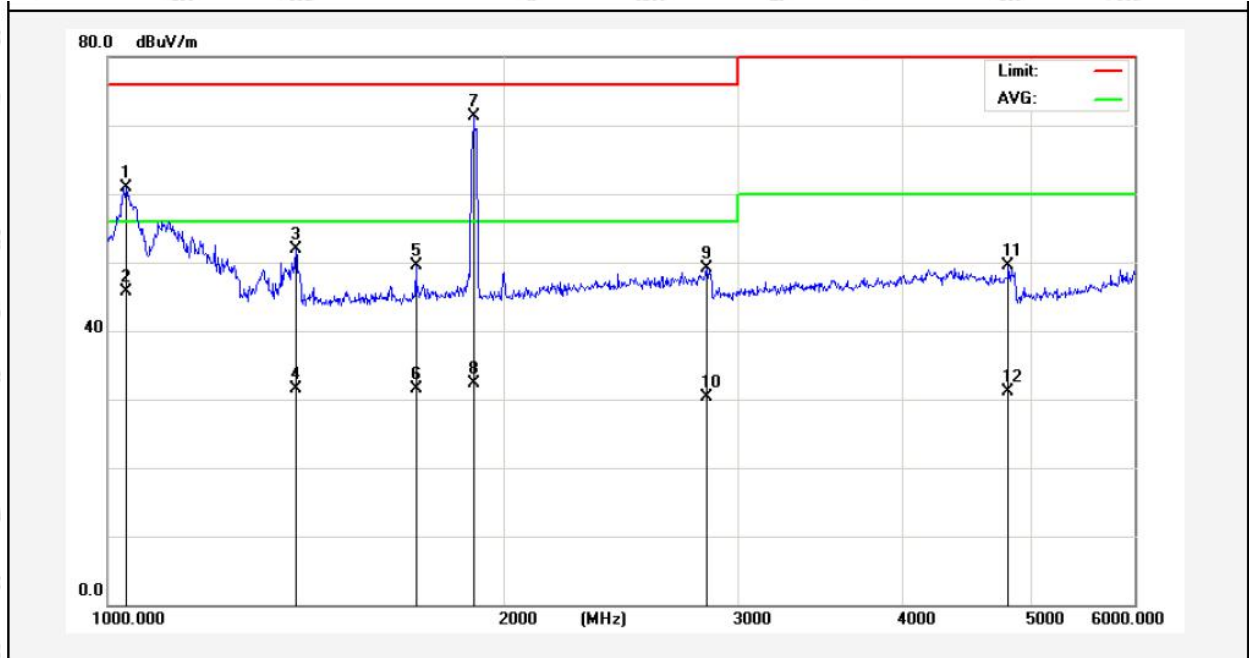

No.	Freq. (MHz)	Reading (dBuV)	Factor (dB/m)	Result (dBuV/m)	Limit (dBuV/m)	Over Limit (dB)	Detector	Height (cm)	degree (deg)	Remark
1	1032.777	58.84	1.97	60.81	76.00	-15.19	peak			
2	1032.777	43.74	1.97	45.71	56.00	-10.29	AVG			
3	1388.039	48.88	2.95	51.83	76.00	-24.17	peak			
4	1388.039	28.50	2.95	31.45	56.00	-24.55	AVG			
5	1711.770	44.10	5.31	49.41	76.00	-26.59	peak			
6	1711.770	26.16	5.31	31.47	56.00	-24.53	AVG			
7	1892.439	64.23	7.05	71.28	76.00	-4.72	peak			
8	1892.439	25.25	7.05	32.30	56.00	-23.70	AVG			
9	2842.249	38.60	10.50	49.10	76.00	-26.90	peak			
10	2842.249	19.72	10.50	30.22	56.00	-25.78	AVG			
11	4813.252	34.38	15.14	49.52	80.00	-30.48	peak			
12	4813.252	15.92	15.14	31.06	60.00	-28.94	AVG			

Note: **Result=Reading+Factor** **Over Limit=Result-Limit**

Test item: Radiation Test **Polarization:** Vertical
Standard: (RE)EN 50121-3-2_Class A_1-6GHz **Power Source:** DC 110V
Distance: 3m **Temp.(°C)/Hum.(%RH):** 23(°C)/54%RH
Test Mode: DP Mode

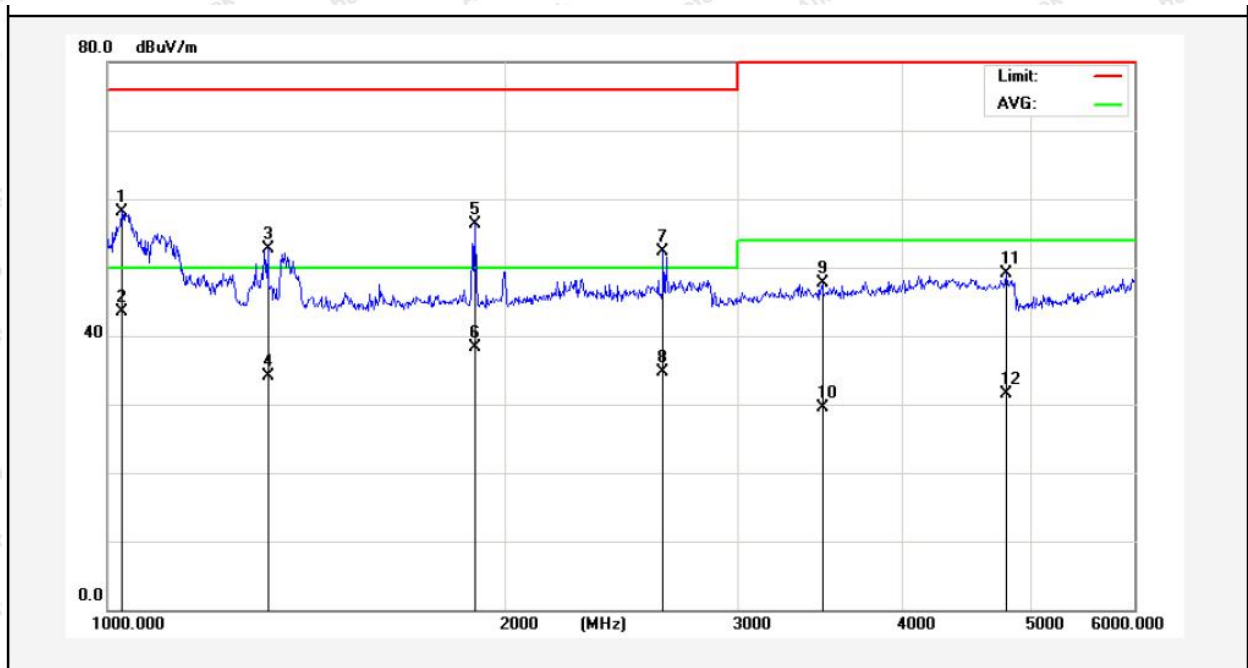

No.	Freq. (MHz)	Reading (dBuV)	Factor (dB/m)	Result (dBuV/m)	Limit (dBuV/m)	Over Limit (dB)	Detector	Height (cm)	degree (deg)	Remark
1	1025.402	56.25	1.95	58.20	76.00	-17.80	peak			
2	1025.402	41.53	1.95	43.48	50.00	-6.52	AVG			
3	1322.488	49.96	2.78	52.74	76.00	-23.26	peak			
4	1322.488	31.35	2.78	34.13	50.00	-15.87	AVG			
5	1899.233	49.16	7.12	56.28	76.00	-19.72	peak			
6	1899.233	31.14	7.12	38.26	50.00	-11.74	AVG			
7	2636.209	42.49	9.83	52.32	76.00	-23.68	peak			
8	2636.209	24.79	9.83	34.62	50.00	-15.38	AVG			
9	3480.112	35.58	12.20	47.78	80.00	-32.22	peak			
10	3480.112	17.23	12.20	29.43	54.00	-24.57	AVG			
11	4796.035	33.95	15.12	49.07	80.00	-30.93	peak			
12	4796.035	16.32	15.12	31.44	54.00	-22.56	AVG			

Note: Result=Reading+Factor Over Limit=Result-Limit

4. Electrostatic Discharge Immunity Test

4.1. Test Standard and Level

Test Standard:	EN 50155 (IEC 61000-4-2)
Performance Criterion:	B
Severity Level: 3 / Air Discharge: $\pm 8\text{kV}$, Level: 3 / Contact Discharge: $\pm 6\text{kV}$	

Test Level

Level	Test Voltage Contact Discharge (kV)	Test Voltage Air Discharge (kV)
1.	± 2	± 2
2.	± 4	± 4
3.	± 6	± 8
4.	± 8	± 15
X.	Special	Special

4.2. Test Setup

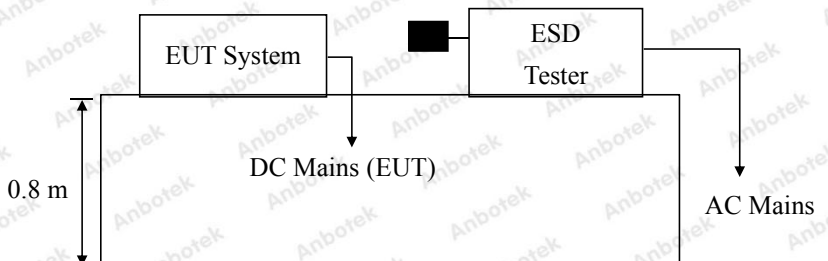

4.3. EUT Configuration on Measurement

The following equipments are installed on electrostatic discharge immunity measurement to meet EN 50155 requirements and operating in a manner which tends to maximize its emission characteristics in a normal application.

4.4. Operating Condition of EUT

- 4.4.1. Setup the EUT as shown on Section 4.2.
- 4.4.2. Turn on the power of all equipments.
- 4.4.3. After that, let the EUT work in test mode measure it.

4.5. Test Procedure

4.5.1. Air Discharge:

This test is done on a non-conductive surface. The round discharge tip of the discharge electrode shall be approached as fast as possible to touch the EUT. After each discharge, the discharge electrode shall be removed from the EUT. The generator is then re-triggered for a new single discharge and repeated 10 times for each pre-selected test point. This procedure shall be repeated until all the air discharge completed

4.5.2. Contact Discharge:

All the procedure shall be same as Section 4.5.1. except that the tip of the discharge electrode shall touch the EUT before the discharge switch is operated.

4.5.3. Indirect discharge for horizontal coupling plane

At least 20 single discharges shall be applied to the horizontal coupling plane, at points on each side of the EUT. The discharge electrode positions vertically at a distance of 0.1m from the EUT and with the discharge electrode touching the coupling plane.

4.5.4. Indirect discharge for vertical coupling plane

At least 20 single discharge shall be applied to the center of one vertical edge of the coupling plane. The coupling plane, of dimensions 0.5m × 0.5m, is placed parallel to, and positioned at a distance of 0.1m from the EUT. Discharges shall be applied to the coupling plane, with this plane in sufficient different positions that the four faces of the EUT are completely illuminated.

4.6. Test Results

PASS

Please refer to the following page.



Electrostatic Discharge Test Results

Air discharge :	±8.0kV	Temperature :	22.5℃
Contact discharge :	±6.0kV	Humidity :	58%
Power Supply :	DC 110V	Criterion required :	B
Number of discharge :	10	Test Result:	<input checked="" type="checkbox"/> Pass <input type="checkbox"/> Fail
Location		Kind A-Air Discharge C-Contact Discharge	Result
Slot of the EUT	6 points	A	<input checked="" type="checkbox"/> A <input type="checkbox"/> B <input type="checkbox"/> C <input type="checkbox"/> D
Metal	10 points	C	<input type="checkbox"/> A <input checked="" type="checkbox"/> B <input type="checkbox"/> C <input type="checkbox"/> D
HCP	4 points	C	<input checked="" type="checkbox"/> A <input type="checkbox"/> B <input type="checkbox"/> C <input type="checkbox"/> D
VCP of the front	4 points	C	<input checked="" type="checkbox"/> A <input type="checkbox"/> B <input type="checkbox"/> C <input type="checkbox"/> D
VCP of the rear	4 points	C	<input checked="" type="checkbox"/> A <input type="checkbox"/> B <input type="checkbox"/> C <input type="checkbox"/> D
VCP of the left	4 points	C	<input checked="" type="checkbox"/> A <input type="checkbox"/> B <input type="checkbox"/> C <input type="checkbox"/> D
VCP of the right	4 points	C	<input checked="" type="checkbox"/> A <input type="checkbox"/> B <input type="checkbox"/> C <input type="checkbox"/> D
Remark: Discharge should be considered on Contact and Air and Horizontal Coupling Plane (HCP) and Vertical Coupling Plane (VCP).			

5. RF Field Strength Susceptibility Test

5.1. Test Standard and Level

Test Standard:	EN 50155 (IEC 61000-4-3)
Required Performance:	A
Frequency Range:	80MHz to 1000MHz/ 1.4 to 2.0 GHz/ 2.0 to 2.7 GHz/ 5.1 to 6.0 GHz
Field Strength:	20V/m & 10V/m & 5V/m & 3V/m
Modulation:	1kHz Sine Wave, 80%, AM Modulation
Frequency Step:	1 % of preceding frequency value
Polarity of Antenna:	Horizontal and Vertical
Test Distance:	3 m
Antenna Height:	1.5 m
Dwell Time:	at least 0.5s

Test Level

Level	Field Strength V/m
1.	1
2.	3
3.	10
X.	Special

5.2. Test Setup

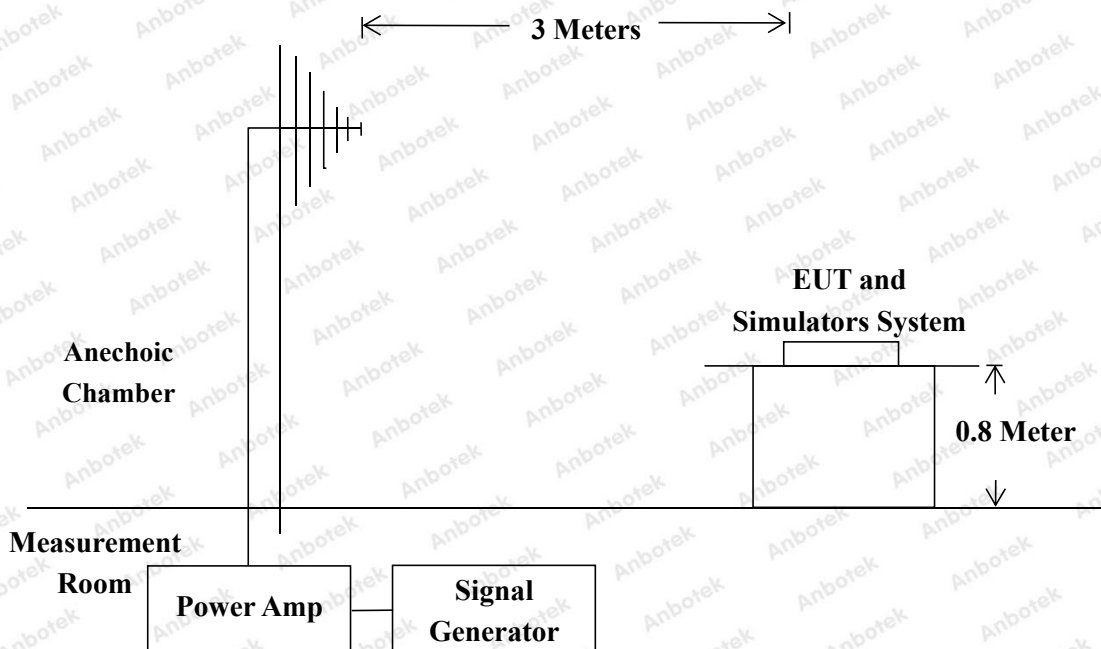

5.3. EUT Configuration on Measurement

The following equipments are installed on RF Field Strength susceptibility Measurement to meet EN 50155 requirements and operating in a manner which tends to maximize its emission characteristics in a normal application.

5.4. Operating Condition of EUT

5.4.1. Setup the EUT as shown on Section 5.2.

5.4.2. Turn on the power of all equipments.

5.4.3. After that, let the EUT work in test mode measure it.

5.5. Test Procedure

The EUT and support equipment, which are placed on a table that is 0.8 meter above ground and the testing was performed in a fully-anechoic chamber. The testing distance from antenna to the EUT was 3 meters.

1) 80 MHz to 1000 MHz the field strength level was 20V/m, 1.4 GHz to 2.0 GHz the field strength level was 10V/m, 2.0 GHz to 2.7 GHz the field strength level was 5V/m, 5.1 GHz to 6.0 GHz the field strength level was 3V/m.

2) The frequency range is swept from 80 MHz to 1000 MHz, 1.4 GHz to 2.0 GHz, 2.0 GHz to 2.7 GHz, 5.1 GHz to 6.0 GHz with the signal 80% amplitude modulated with a 1kHz sine wave.

3) The dwell time at each frequency shall be not less than the time necessary for the EUT to be able to respond, but shall in no case be less than 0.5s.

4) The test was performed with the EUT exposed to both vertically and horizontally polarized fields on each of the four sides.

5.6. Measuring Results

PASS

Please refer to the following page.



RF Field Strength Susceptibility Test Results

Field Strength :	20V/m, 10 V/m 5 V/m, 3V/m	Temperature :	25°C
Criterion required :	A	Humidity :	54%
Power Supply :	DC 110V	Test Result :	<input checked="" type="checkbox"/> Pass <input type="checkbox"/> Fail
Dwell Time:	1s		

Frequency Range	Antenna Polarity	R.F. Field Strength	Azimuth	Result
80MHz~1000MHz	H / V	20 V/m (rms)	Front	<input checked="" type="checkbox"/> A <input type="checkbox"/> B <input type="checkbox"/> C <input type="checkbox"/> D
			Rear	
			Left	
			Right	
1.4GHz~2.0GHz	H / V	10 V/m (rms)	Front	<input checked="" type="checkbox"/> A <input type="checkbox"/> B <input type="checkbox"/> C <input type="checkbox"/> D
			Rear	
			Left	
			Right	
2.0GHz~2.7GHz	H / V	5 V/m (rms)	Front	<input checked="" type="checkbox"/> A <input type="checkbox"/> B <input type="checkbox"/> C <input type="checkbox"/> D
			Rear	
			Left	
			Right	
5.1GHz~6.0GHz	H / V	3 V/m (rms)	Front	<input checked="" type="checkbox"/> A <input type="checkbox"/> B <input type="checkbox"/> C <input type="checkbox"/> D
			Rear	
			Left	
			Right	

6. Electrical Fast Transient/Burst Immunity Test

6.1. Test Standard and Level

Test Standard:	EN 50155 (IEC 61000-4-4)
Performance criterion:	A
DC Main: Severity Level 3: 2.00kV	

Test Level

Open Circuit Output Test Voltage $\pm 10\%$		
Level	On Power Supply Lines	On I/O (Input/Output) Signal data and control lines
1.	0.50 kV	0.25 kV
2.	1.00 kV	0.50 kV
3.	2.00 kV	1.00 kV
4.	4.00 kV	2.00 kV
X.	Special	Special

6.2. Test Setup

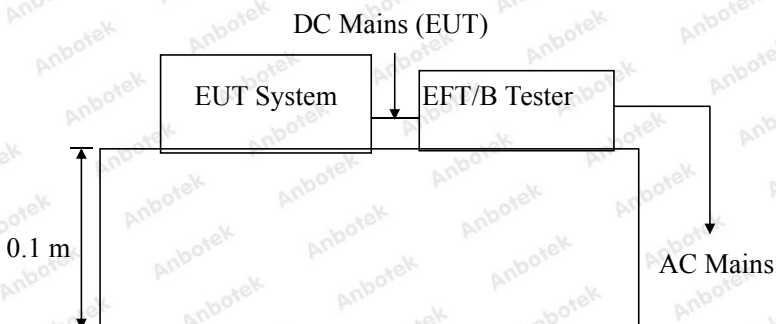

6.3. EUT Configuration on Measurement

The following equipments are installed on electrical fast transient/burst immunity measurement to meet EN 50155 requirements and operating in a manner which tends to maximize its emission characteristics in a normal application.

6.4. Operating Condition of EUT

6.4.1. Setup the EUT as shown in Section 6.2.

6.4.2. Turn on the power of all equipments.

6.4.3. Let the EUT work in test mode and measure it.

6.5. Test Procedure

The EUT is put on the table which is 0.1 meter high above the ground. This reference ground plane shall project beyond the EUT by at least 0.1m on all sides and the minimum distance between EUT and all other conductive structure, except the ground plane beneath the EUT, shall be more than 0.5m.

6.5.1. For input and output DC power ports:

The EUT is connected to the Power mains by using a coupling device which couples the EFT interference signal to DC Power lines. Both polarities of the test voltage should be applied during compliance test and the duration of the test is 2 mins.

6.5.2. For signal lines and control lines ports:

Select tests based on product characteristics.

6.5.3. For DC output line ports:

Select tests based on product characteristics.

6.6. Test Results

PASS

Please refer to the following page.



Electrical Fast Transient/Burst Test Results

Ambient Condition : 22.5°C / 58% RH		Criterion required : A	
Power Supply : DC 110V		Test Result : <input checked="" type="checkbox"/> Pass <input type="checkbox"/> Fail	
Inject Line : DC Mains		Inject Method: Direct	Inject Time(s): 120
Line	Polarity	Test Voltage (kV)	Result
AC Line			
DC Line	±	2.00kV	<input checked="" type="checkbox"/> A <input type="checkbox"/> B <input type="checkbox"/> C <input type="checkbox"/> D
Signal Line			

7. Surge Immunity Test

7.1. Test Standard and Level

Test Standard:	EN 50155 (IEC 61000-4-5)
Performance criterion:	B
Severity Level 2, Line to Line: 1.0kV; Severity Level 3, Line to Earth: 2.0kV	

Test Level

Severity Level	Open-Circuit Test Voltage (kV)
1.	0.5
2.	1.0
3.	2.0
4.	4.0
X.	Special

7.2. Test Setup

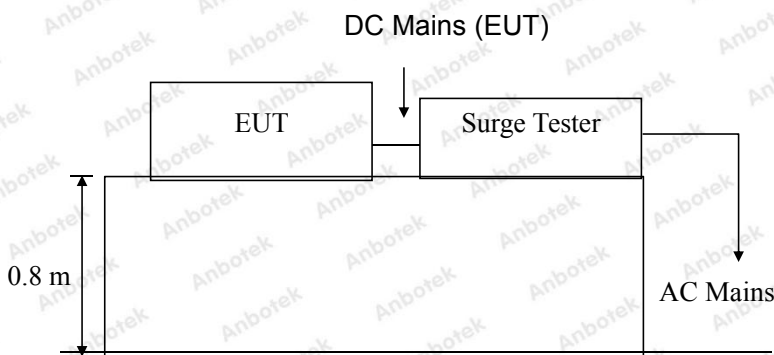

7.3. EUT Configuration on Measurement

The following equipments are installed on surge immunity measurement to meet EN 50155 requirements and operating in a manner which tends to maximize its emission characteristics in a normal application.

7.4. Operating Condition of EUT

- 7.4.1. Setup the EUT as shown in Section 7.2.
- 7.4.2. Turn on the power of all equipments.
- 7.4.3. Let the EUT work in test mode and measure it.

7.5. Test Procedure

7.5.1. Set up the EUT and test generator as shown on Section 7.2.

7.5.2. For line to line coupling mode, provide a 1.0 kV 1.2/50us voltage surge (at open-circuit condition) and 8/20us current surge to EUT selected points.

7.5.3. For line to earth coupling mode, provide a 2.0 kV 1.2/50us voltage surge (at open-circuit condition) and 8/20us current surge to EUT selected points.

7.5.4. At least 5 positive and 5 negative (polarity) tests with a maximum 1/min repetition rate are conducted during test.

7.5.5. Different phase angles are done individually.

7.5.6. Record the EUT operating situation during compliance test and decide the EUT immunity criterion for above each test.

7.6. Test Results

PASS

Please refer to the following page.



Surge Immunity Test Results

Humidity :	58%	Temperature :	22.5°C		
Power Supply :	DC 110V	Criterion required:	A		
Test Result :	<input checked="" type="checkbox"/> Pass <input type="checkbox"/> Fail				
Location	Polarity	Phase Angle	Number of Pulse	Pulse Voltage (kV)	Result
Positive-Negative	±	/	5	1.0kV	<input checked="" type="checkbox"/> A <input type="checkbox"/> B <input type="checkbox"/> C <input type="checkbox"/> D
Positive-PE	±	/	5	2.0kV	<input checked="" type="checkbox"/> A <input type="checkbox"/> B <input type="checkbox"/> C <input type="checkbox"/> D
Negative-PE	±	/	5	2.0kV	<input checked="" type="checkbox"/> A <input type="checkbox"/> B <input type="checkbox"/> C <input type="checkbox"/> D

8. Injected Currents Susceptibility Test

8.1. Test Standard and Level

Test Standard:	EN 50121-3-2 (IEC 61000-4-6)
Performance criterion:	A
Severity Level 3: 10V (rms), (0.15MHz ~80MHz)	

Test Level

Level	Field Strength V
1.	1
2.	3
3.	10
X.	Special

8.2. Test Setup

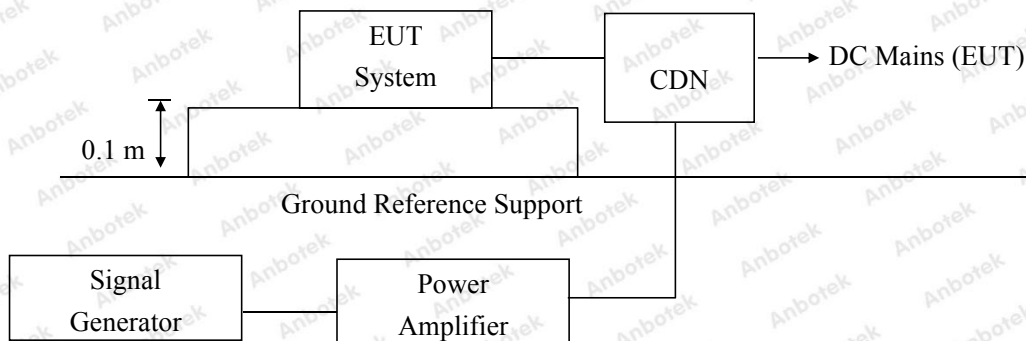

8.3. EUT Configuration

The following equipments are installed on currents susceptibility measurement to meet EN 50155 requirements and operating in a manner which tends to maximize its emission characteristics in a normal application.

8.4. Operating Condition of EUT

- 8.4.1. Setup the EUT as shown in Section 8.2.
- 8.4.2. Turn on the power of all equipments.
- 8.4.3. Let the EUT work in test mode and measure it.

8.5. Test Procedure

- 1) Set up the EUT, CDN and test generators as shown on Section 8.2.
- 2) Let the EUT work in test mode and measure it.
- 3) The EUT are placed on an insulating support 0.1m high above a ground reference plane. CDN (coupling and decoupling device) is placed on the ground plane about 0.3m from EUT. Cables between CDN and EUT are as short as possible, and their height above the ground reference plane shall be between 30 and 50 mm (where possible).
- 4) The disturbance signal described below is injected to EUT through CDN.
- 5) The EUT operates within its operational mode(s) under intended climatic conditions after power on.
- 6) The frequency range is swept from 150KHz to 80MHz using 10V signal level, and with the disturbance signal 80% amplitude modulated with a 1KHz sine wave.
- 7) The rate of sweep shall not exceed 1.5×10^{-3} decades/s. Where the frequency is swept incrementally, the step size shall not exceed 1% of the start and thereafter 1% of the preceding frequency value.
- 8) Recording the EUT operating situation during compliance testing and decide the EUT immunity criterion.

8.5.1. For signal lines and control lines ports:

Select tests based on product characteristics.

8.5.2. For DC output line ports:

Select tests based on product characteristics.

8.6. Test Results

PASS

Please refer to the following page.



Injected Currents Susceptibility Test Results

Humidity : 55%		Temperature : 23°C	
Power Supply : DC 110V		Criterion required: A	
Test Result : <input checked="" type="checkbox"/> Pass <input type="checkbox"/> Fail			
Frequency Range (MHz)		Strength (Unmodulated)	
0.15 ~ 80		10V	
Injected Position		Result	
DC Mains		<input checked="" type="checkbox"/> A <input type="checkbox"/> B <input type="checkbox"/> C <input type="checkbox"/> D	
Remark : 1. Modulation Signal:1KHz 80% AM			

9. Magnetic Field Susceptibility Test

9.1. Test Standard and Level

Test Standard:	EN 50155 (IEC 61000-4-8)
Performance Criterion:	A
Severity Level 4: 30A /m	
Severity Level 4: 300A/m	

Test levels for continuous field

Level	Field Strength A/m
1.	1
2.	3
3.	10
4.	30
5.	100
X.	Special

Test levels for short duration: 1 s to 3 s

Level	Field Strength A/m
1.	/
2.	/
3.	/
4.	300
5.	1000
X.	Special

9.2. Test Setup

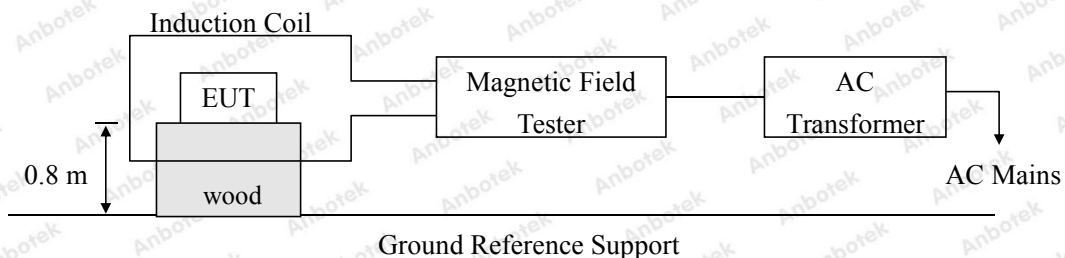

9.3. EUT Configuration on Measurement

The following equipments are installed on magnetic field susceptibility measurement to meet EN 50155 requirements and operating in a manner which tends to maximize its emission characteristics in a normal application.

9.4. Operating Condition of EUT

9.4.1. Setup the EUT as shown in Section 9.2.

9.4.2. Turn on the power of all equipments.

9.4.3. Let the EUT work in test mode and measure it.

9.5. Test Procedure

The EUT is placed in the middle of a induction coil (1*1m), under which is a 1*1*0.1m (high)table, this small table is also placed on a larger table, 0.8 m above the ground.

Both horizontal and vertical polarization of the induction coil are set on test, so that each side of the EUT is affected by the magnetic field. Also can reach the same aim by change the position of the EUT.

9.6. Test Results

PASS

Please refer to the following page.



Magnetic Field Immunity Test Results

Temperature : 22.5°C		Humidity : 58%	
Power Supply : DC 110V		Criterion required : A	
Test Result : <input checked="" type="checkbox"/> Pass <input type="checkbox"/> Fail			
Test Level (A/M)	Testing Duration	Coil Orientation	Result
30	5 mins	X	<input checked="" type="checkbox"/> A <input type="checkbox"/> B <input type="checkbox"/> C <input type="checkbox"/> D
30	5 mins	Y	<input checked="" type="checkbox"/> A <input type="checkbox"/> B <input type="checkbox"/> C <input type="checkbox"/> D
30	5 mins	Z	<input checked="" type="checkbox"/> A <input type="checkbox"/> B <input type="checkbox"/> C <input type="checkbox"/> D
Test Level (A/M)	Testing Duration	Coil Orientation	Result
300	3s	X	<input checked="" type="checkbox"/> A <input type="checkbox"/> B <input type="checkbox"/> C <input type="checkbox"/> D
300	3s	Y	<input checked="" type="checkbox"/> A <input type="checkbox"/> B <input type="checkbox"/> C <input type="checkbox"/> D
300	3s	Z	<input checked="" type="checkbox"/> A <input type="checkbox"/> B <input type="checkbox"/> C <input type="checkbox"/> D

APPENDIX I -- TEST SETUP PHOTOGRAPH

Photo of Power Line Conducted Emission Test



Photo of Radiated Emission Test



Photo of Electrostatic Discharge Immunity Test



Photo of RF Field Strength susceptibility Test

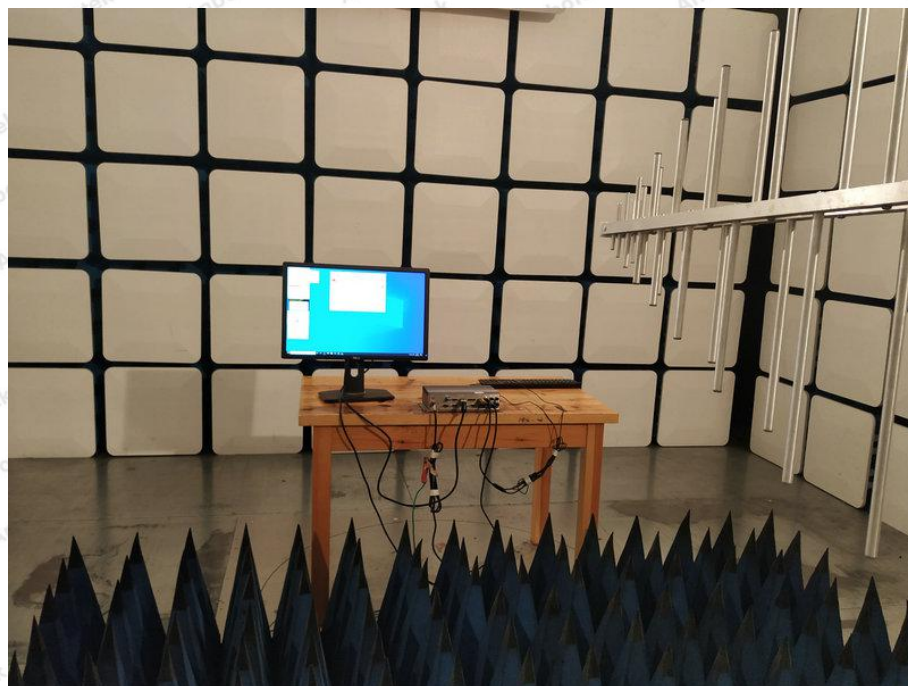

Photo of Electrical Fast Transient/Burst Immunity Test



Photo of Surge Immunity Test

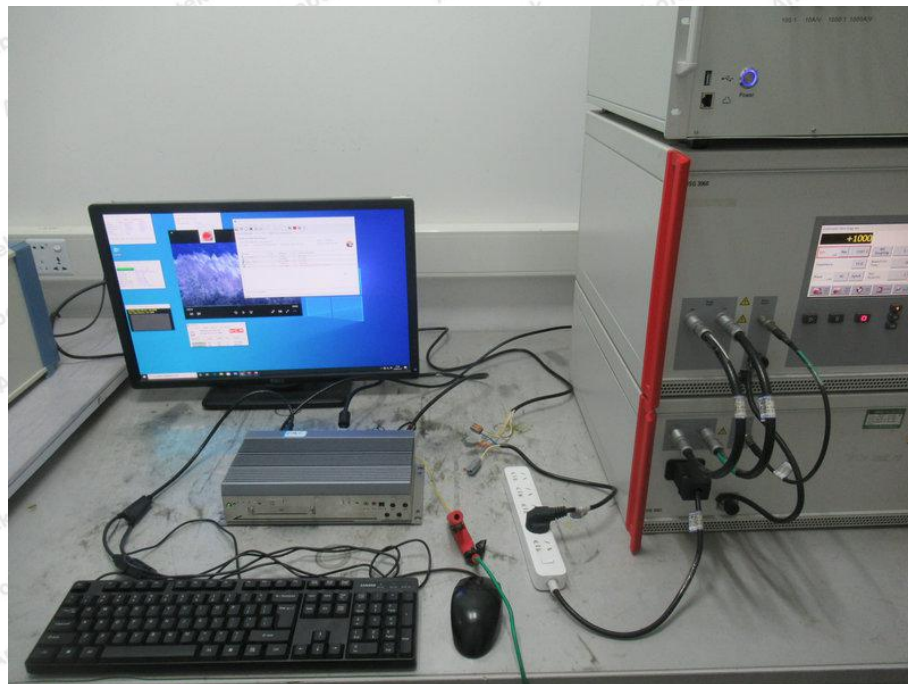
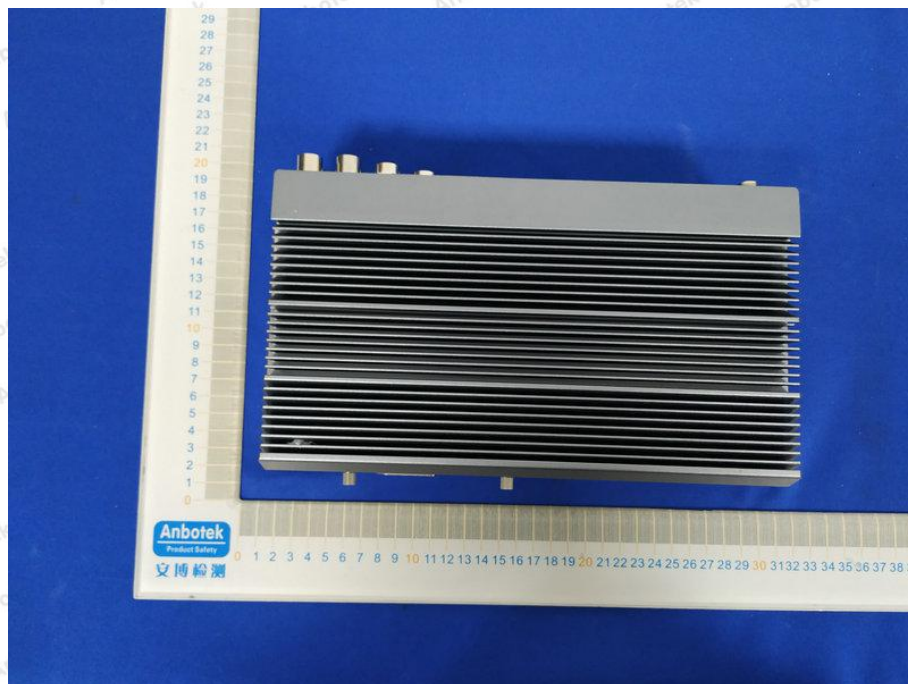
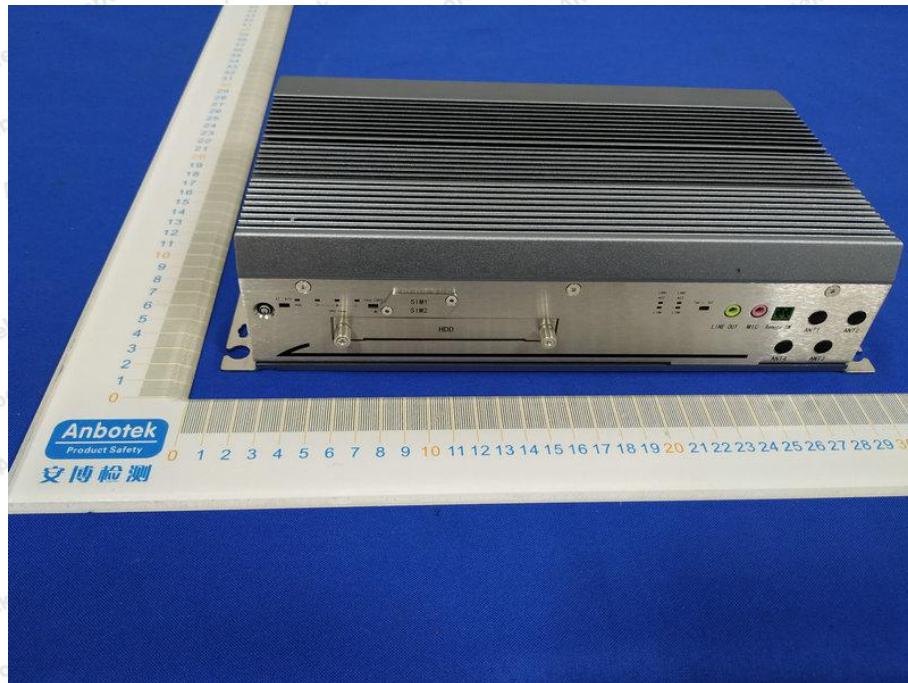
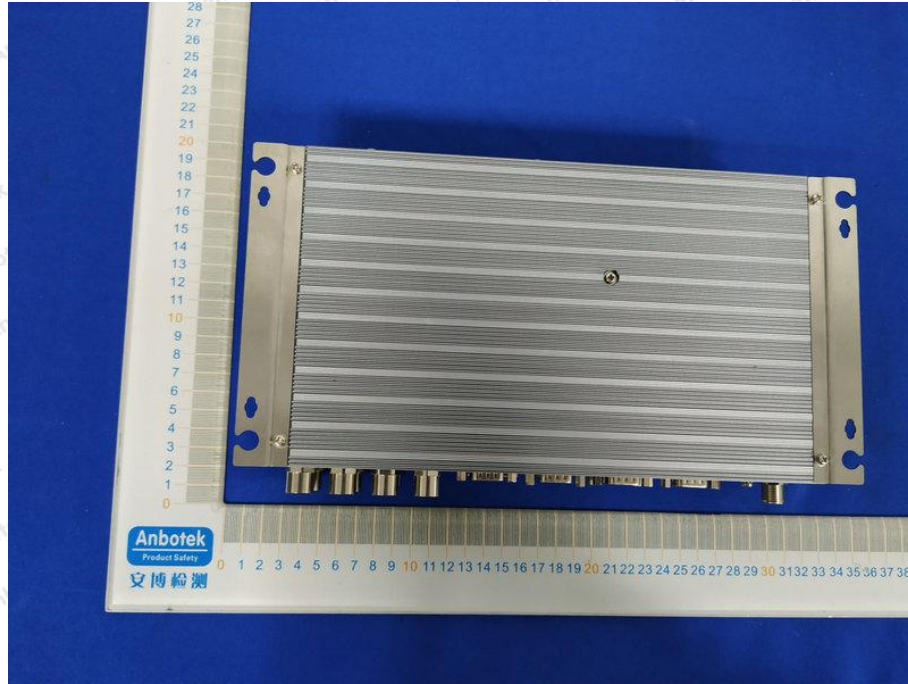

Photo of Injected currents susceptibility Test



APPENDIX II -- EXTERNAL PHOTOGRAPH





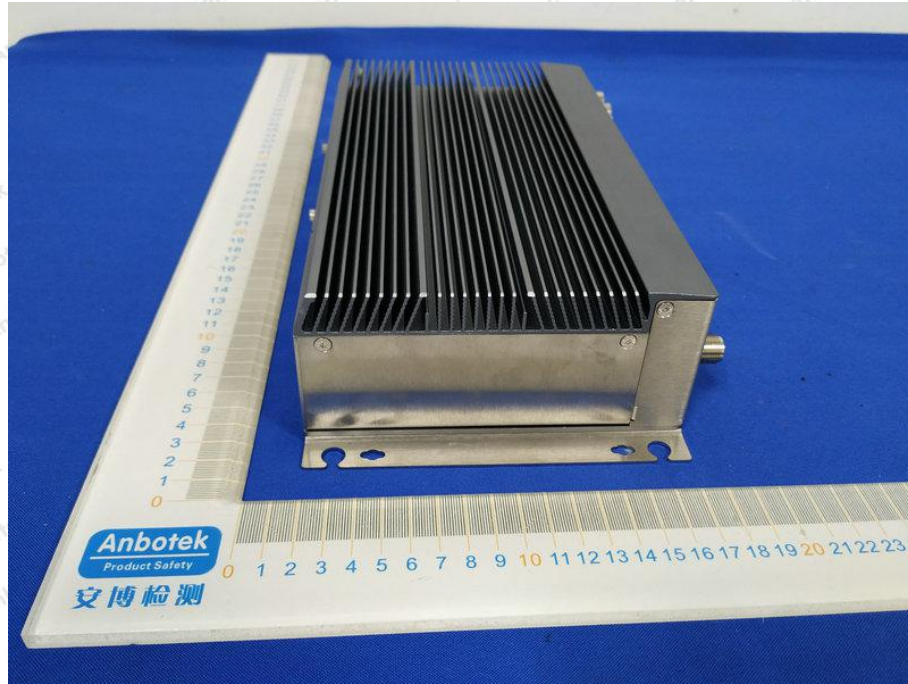

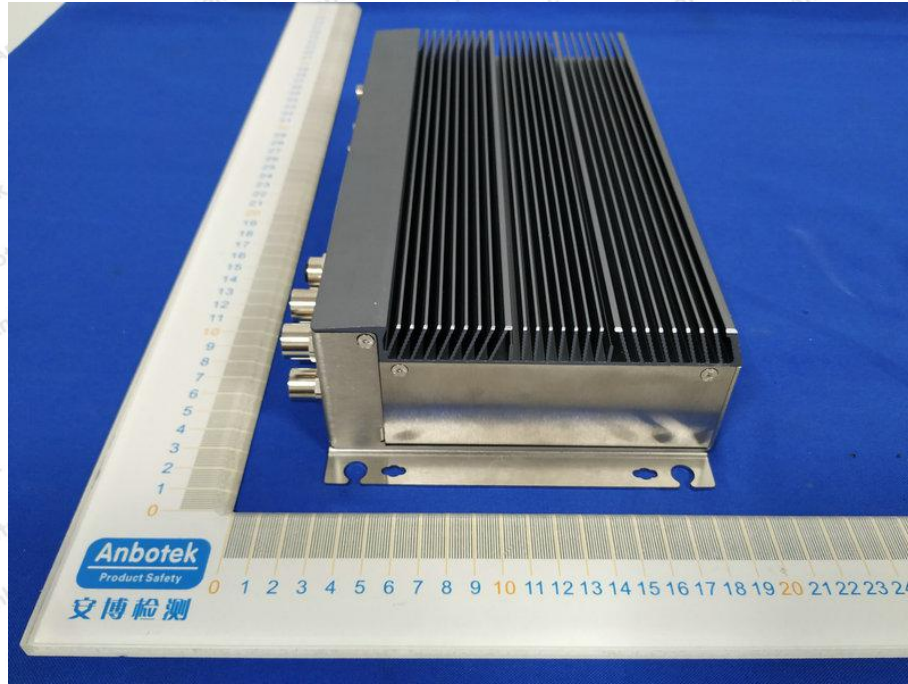

APPENDIX III -- INTERNAL PHOTOGRAPH

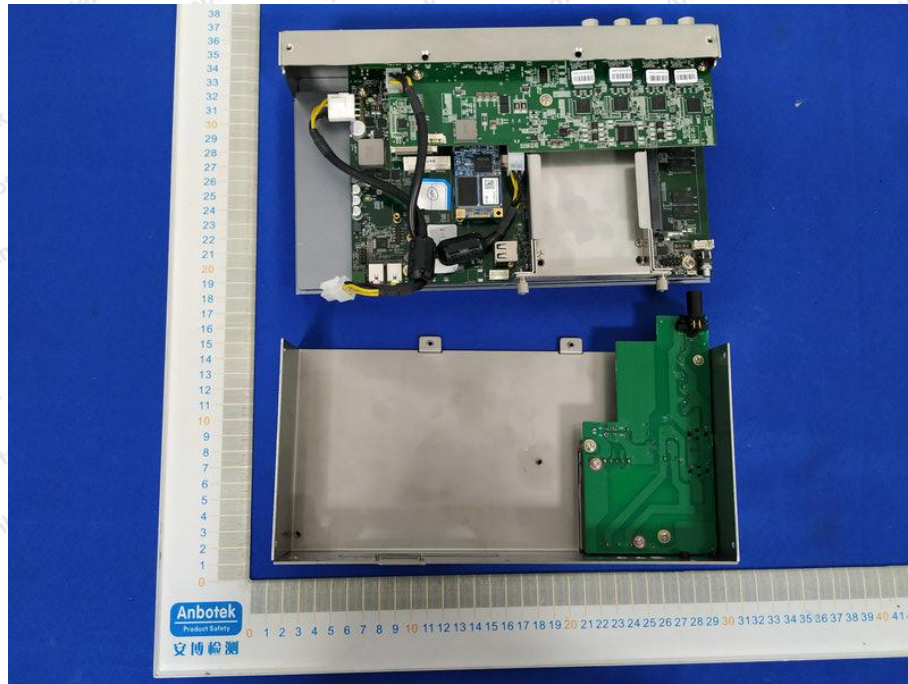

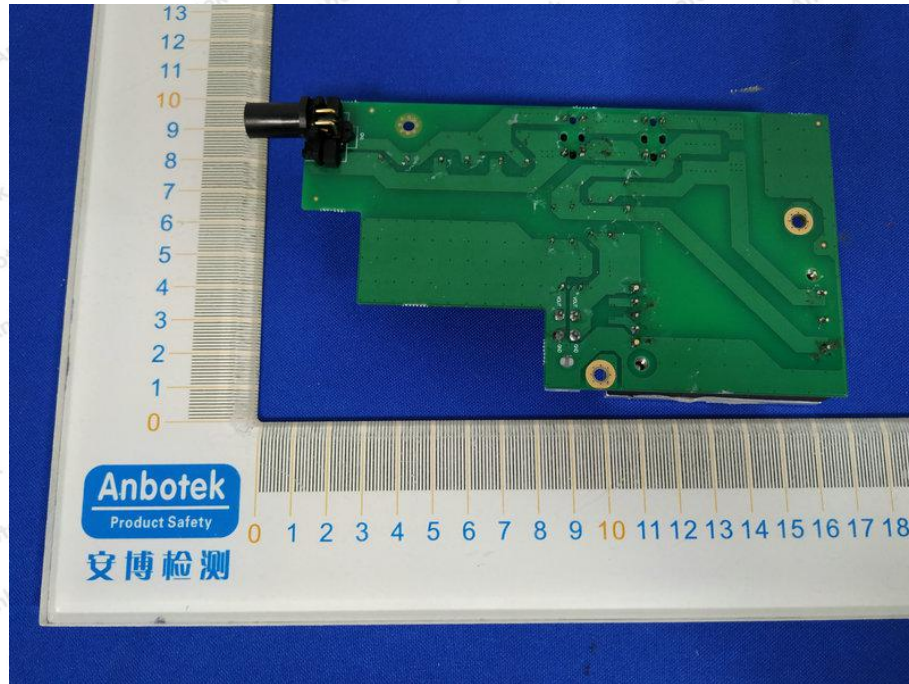

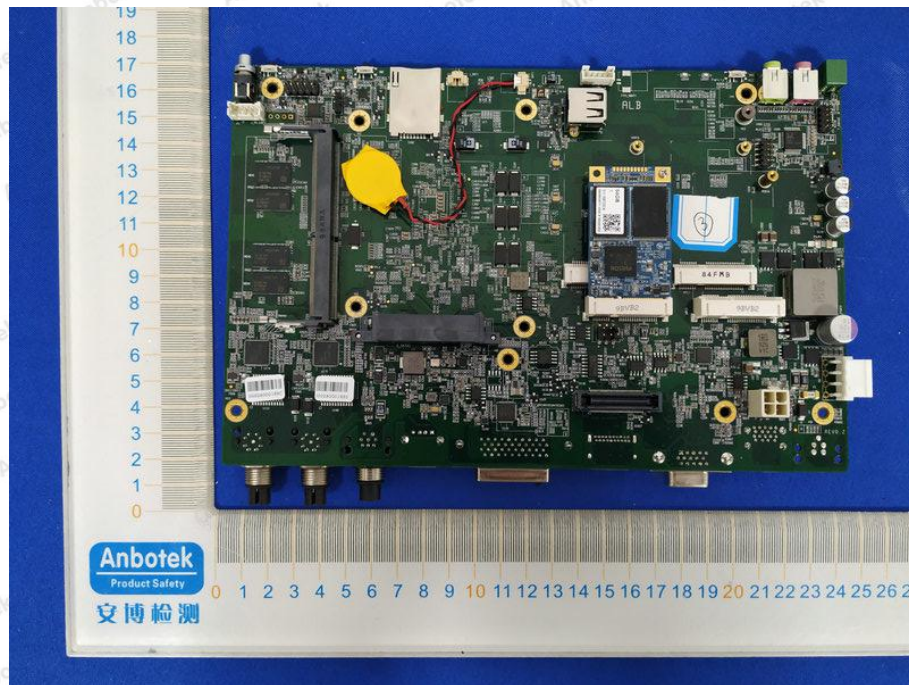
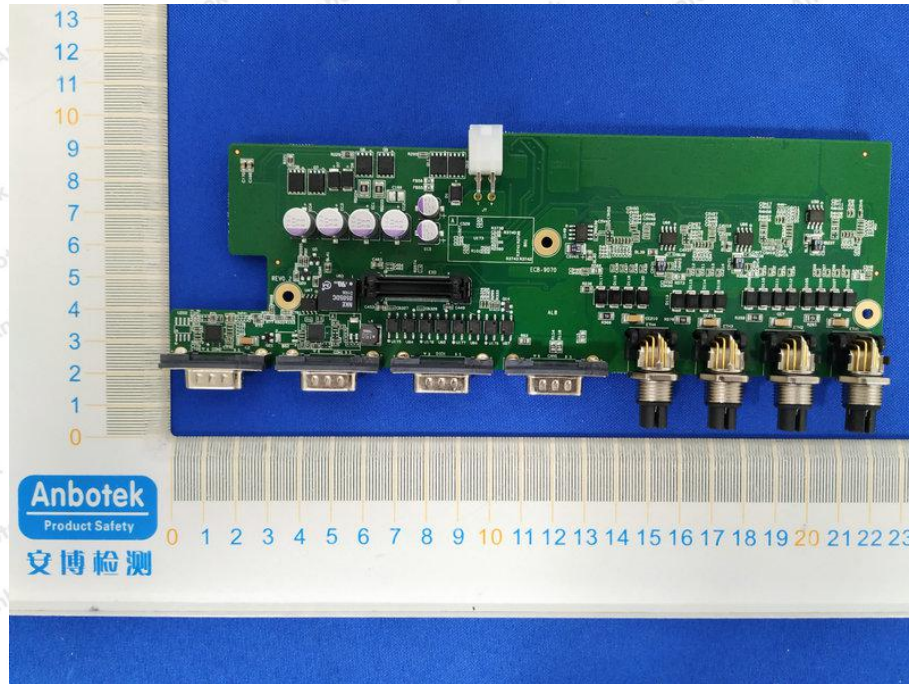

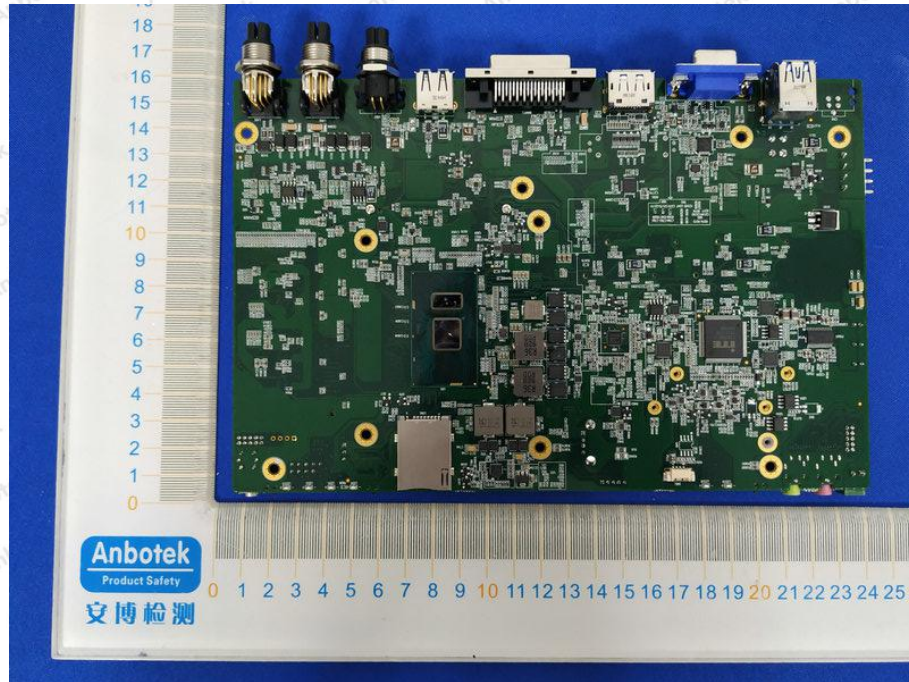

CE Label

1. The CE conformity marking must consist of the initials 'CE' taking the following form:

If the CE marking is reduced or enlarged, the proportions given in the above graduated drawing must be respected.

2. The CE marking must have a height of at least 5 mm except where this is not possible on account of the nature of the apparatus.

3. The CE marking must be affixed to the product or to its data plate. Additionally it must be affixed to the packaging, if any, and to the accompanying documents.

4. The CE marking must be affixed visibly, legibly and indelibly.

It must have the same height as the initials 'CE'.

----- End of Report -----

